



1813 "E" Avenue • P.O. Box 5057 • Sioux Falls, SD 57117-5057 • (605) 338-AERO

SERVICE LETTER 101

Date: September 29, 1986

Authorized Aerostar/Raven Repair Stations

From: Aerostar International Inc.

Retrofit of Latest Deflation/Vent Panel Attachment Method

Attached you will find instructions for revising the Spring Top deflation/vent panel in S-55, S-60, S-66 and RX-7 Aerostar/Raven balloons to their revision as of this service letter date. This update of the deflation panel will increase the vent area and increase the effectivity of that vent. It is recommended but not required.

It is a simple task to perform this operation but it must be done by a authorized Aerostar/Raven repair station only. Some techniques described in the enclosed instructions are more detailed in the Aerostar Instructions for Continuing Airworthiness; for example the Stitch Type 301, also tolerances of double needle gauge and sewing of hook and pile fastener tape. It is therefore necessary to have this manual for this operation.

A FAA Form 337 is also required for this alteration, where this service letter is used as "previously approved data" and approval for return to service may be executed by a certificated mechanic or aircraft inspector. File the original copy of the form with the aircraft owner/operator and one copy with the local FAA district office.

The following define the type of materials required for this retrofit operation:

1) 1" Tape, Mil-I-5038 Type IV, [Aerostar 51047-16 or equivalent] will be referred to from now forth as "1" webbing".

2) 1 1/2" Tape, Mil-I-5038 Type IV, [Aerostar 51047-50] will be referred to from now forth as "1 1/2" webbing".

3) 1" Hook Fastener Tape, Mil-F-21840, [Aerostar 51048-02] will be referred to from now forth as "velcro hook".

4) 1" Pile Fastener Tape, Mil-F-21840, [Aerostar 51048-03] will be referred to from now forth as "velcro pile".

5) "E" thread, Polyester U-T-285, Type I or II, Class 1 or 3, 2 twist, will be referred to from now forth as "E" thread.

6) "F" thread, Polyester U-T-285, Type I or II, Class 1 or 3, 2 twist, will be referred to from now forth as "F" thread.

7) Polyurethane Coated one side, Single or Double Rip-Stop Hot Air Balloon Fabric, Aerostar approved [Aerostar B-07733 or S1009-##], will be referred to from now forth as "balloon fabric".

8) 550 lb. Nylon Cord, Mil-C-5040-T3 [Aerostar 51047-10] will be from now forth referred to as "parachute cord".

INSTRUCTIONS TO UPGRADE PARAVENT OF MODELS S-55 & S-60 ENVELOPE

These instructions define the method which is being used at the time of issuance of this letter to install the deflation panel. Balloons which were built prior to April 30, 1986 may be refitted as described herein.

Before starting this retrofit, verify that the cap to envelope attachment is not as described in Detail "I". If your envelope is attached as depicted, the Paravent is the latest revision.

1. Begin by preparing the parts needed:

2 pcs. 1" webbing 14"

2 pcs. 1" webbing 28"

6 pcs. 1" webbing 16"

2 pcs. 1" webbing 4"

2 pcs. 1" velcro pile 4" long

2 pcs. 1" velcro hook 4" long

2 pcs. balloon fabric 8" x 32" color matched to top cap

If the cap is not attached to the innermost spider-web intersection (closest circumferential band to center of top), the following items are also required:

5 pcs. balloon fabric 6" x 14" color matched to top cap.

Before proceeding any farther, verify that the seam locations are marked on the edge of the top cap for seams 2 through 18 and 48. Number any of those that are not previously numbered.

2. Detach the top cap from the envelope by carefully cutting the stitching away that fastens the two together. Leave the 1-1/2" webbing buffer on the outside of the envelope.

** If the top cap is attached to the circumferential band closest to the center of the spider web, skip steps 3, 5 and 10.

3. Detach the top cap from the spider webbing by cutting the bartack stitching.

NOTE

All sewing performed in the following steps to use type 301 stitch;
7 to 11 stitches per inch.

4. Prepare the cap for reattachment to the envelope.
 - a. At locations 18 and 48 cut the stitching to free the 1-1/2" webbing away from the cap about 5" to 6" in both directions.
 - b. Fold the 8" x 32" fabric in half to form an 8" x 16" double layer buffer. Sew this to the cap underneath the 1-1/2" webbing as shown in detail T with a 3/8" gage stitch and "E" thread.
 - c. Sew the 14" long 1" webbing on next with a 3/8" gage and "E" thread, backstitching the free end. Sew the 1-1/2" webbing back down to the cap with a 3/4" gage and "E" thread.
5. The next task is to prepare the cap for reattachment to the spider web.
 - a. Locate the center of the cap. Project a radial from seam 5 at the cap edge to the cap center. Mark the location along this radial at 76" from the cap edge for the S-55, 78.5" for the S-60. Do the same for seams 7, 9, 11 and 13.
 - b. Mark an arc 6" before seam 5 extending to 6" past seam 13 through the marked locations from the cap edge. (see cap sketch).
 - c. Fold the 6" x 14" pieces as shown in detail B to make buffers that measure 4" x 6". Hold the folds in place with pins and sew them onto the outside of the top cap with 3/8" gage and "E" thread. See detail C.
 - d. Sew the 1-1/2" buffer web to the inside of the cap from location 5 to 13 starting 6" from 5 and extending 6" beyond 13 with 3/4" gage and "E" thread.

NOTE

Do not remove the existing 1-1/2" web and patch buffers from the cap.

6. Attach the 28" long webbings to the cap to provide the loops for the vent side lines at seams 2 and 16. See detail J.
 - a. Sew on the webbing with 3/8" gage "E" thread first, backstitch the ends. Seams 2 and 16.
 - b. Use a single needle machine with "F" thread to sew a box-x at the position shown in detail J.
 - c. Finally, sew on the 4" long pile with a box stitch as shown in detail J, single needle with "F" thread.

7. Install two "stickmen" at station 62.75 for the S-55, station 72 for the S-60, at gores 2 & 16. Refer to detail S. Note: this is a simplified version which does not require a zig-zag stitch. Use a single needle with "F" thread. Ensure that none of the stitching of the verticle webbing passes above the uppermost line of stitching of the horizontal webbing.
8. Sew the 4" velcro hook on the inside of the envelope with the 4" webbing buffer on the outside at seams 2 and 16, 8" down from the port opening. See detail D. Use a single needle with "F" thread.
9. Attach the top cap to the envelope at seams 18 & 48. See detail T.
 - a. Sew the edge of the cap to the envelope with a box-x where the 1-1/2" webbing buffer is located on the outside. Single needle "F" thread.
 - b. Place the foot of the machine on the first box-x and while pulling the cap and envelope taut, make a mark on the cap at the edge of the port opening.
 - c. Measure 1/2" further away from the box-x and make another mark.
 - d. Slide the cap under the port opening until the edge lines up with the second mark and sew the two together with another box-x.

Attach the top cap to the spider web with a box-x stitch as shown in detail C. Single needle "F" thread

Attach the parachute lines to the cap with a beckett's loop, then to the "stickmen" with a bowline loop, and the other end to the pull line with another bowline loop. The length from cap to stickman is 101" for S-55, 111" for the S-60. From cap to pull line is 16'-8" for the S-55, 18'-6" for the S-60 at seam 2 and 22'-1" for the S-55, 24'-10" for the S-60 at seam 16. Dimensions are measured loop to loop. Safety knots at all bowline knots.

INSTRUCTIONS TO UPGRADE PARAVENT OF MODEL S-66 ENVELOPE

These instructions define the method which is being used at the time of issuance of this letter to install the deflation/vent panel. Balloons which were built prior to April 30, 1986 may be refitted as described herein.

Before starting this retrofit, verify that the cap to envelope attachment is not as described in Detail "T". If your envelope is attached as depicted, the deflation/vent panel is the latest revision.

1. Begin by preparing the parts needed:

- 2 pcs. 1" webbing 17"
- 2 pcs. 1" webbing 28" long
- 6 pcs. 1" webbing 16"
- 2 pcs. 1" webbing 4" long
- 2 pcs. 1" velcro pile 4" long
- 2 pcs. 1" velcro hook 4" long

If the cap is not attached to the innermost spider-web intersection [closest circumferential band to the center of top], the following items are required:

- 5 pcs. balloon fabric 6" x 14" color matched to top cap.

Before proceeding any farther, verify that the seam locations are marked on the edge of the top cap for seams 2 through 18 and 48. Number any of those that were not previously numbered.

2. Detach the top cap from the envelope by carefully cutting the stitching away that fastens the two together. Leave the 1-1/2" webbing buffer on the outside of the envelope.

** If the top cap is attached to the circumferential band closest to the center of the spider web, skip steps 3, 5 and 10.

3. Detach the top cap from the spider webbing by cutting the bartack stitching.

NOTE

All sewing performed in the following steps to use type stitching: 7 to 11 stitches per inch.

4. Prepare the cap for reattachment to the envelope
 - a. At seams 18 and 48 cut the stitching to free the 1-1/2" webbing away from the cap about 5"-6" in both directions.
 - b. Fold the 8" x 40" fabric in half to form an 8" x 20" double layer buffer. Sew this to the cap underneath the 1-1/2" webbing as shown in detail I with a 3/8" gage stitch and "E" thread.
 - c. Sew the 17" long 1" webbing on next with a 3/8" gage and "E" thread, backstitching the free end. Sew the 1-1/2" webbing back down to the cap with a 3/4" gage and "E" thread.

5. The next task is to prepare the cap for reattachment to spider web.
 - a. Locate the center of the cap. Project a radial from seam 5 at the cap edge to the cap center. Mark the location along this radial at 81" from the cap edge. Do the same for seams 7, 9, 11 and 13.
 - b. Mark an arc 6" before seam 5 extending to 6" past seam 13 through the marked locations measured from the cap edge. [see cap sketch]
 - c. Fold the 6" x 14" pieces as shown in detail B to make buffers that measure 4" x 6". Hold the folds in place with pins and sew them onto the outside of the top cap with 3/8" gage and "E" thread. See detail C.
 - d. Sew the 1-1/2" buffer web to the inside of the cap from seam 5 to 13 starting 6" before 5 and extending 6" beyond 13 with 3/4" gage and "E" thread.

NOTE

Do not remove existing 1-1/2" web and patch buffers from the cap.

6. Attach the 28" long webbings to the cap to provide the loops for the vent side lines. See detail J.
 - a. Sew on the webbing with 3/8" gage "E" thread first, backstitch the ends. Seams 2 and 16.
 - b. Use a single needle machine with "F" thread to sew a box-x at the position shown in detail J.
 - c. Finally, sew on the 4" long pile with a box stitch as shown in detail J, single needle with "F" thread.

7. Install two "stickmen" at station 78 at gores 2 & 16. Refer to detail S. Note: this is a simplified version which does not require a zig-zag stitch. Use a single needle with "F" thread. Ensure that none of the stitching of the verticle webbing passes above the uppermost line of stitching of the horizontal webbing.
8. Sew the 4" velcro hook on the inside of the envelope with the 4" webbing buffer on the outside at seams 2 and 16, 11" down from the port opening. See detail D. Use a single needle with "F" thread.
9. Attach the top cap to the envelope at seams 18 & 48. See detail T.
 - a. Sew the edge of the cap to the envelope with a box-x where the 1-1/2" webbing buffer is located on the outside. Single needle "F" thread.
 - b. Place the foot of the machine on the first box-x and pulling the cap and envelope taut, make a mark on the cap at the edge of the port opening.
 - c. Measure 1/2" further away from the box-x and make another mark.
 - d. Slide the cap under the port opening until the edge lines up with the second mark and sew the two together with another box-x.

Attach the top cap to the spider web with a box-x stitch as shown in detail C. Single needle "F" thread.

Attach the parachute lines to the cap with a beckett's loop, then to the "stickmen" with a bowline loop, and the other end to the pull line with another bowline loop. The length from cap to stickman is 127". From cap to pull line is 21'-0" at seam 2 and 26'-7" at seam 16. Dimensions are measured loop to loop. Safety knots at all bowline knots.

SERVICE LETTER 101 PAGE 7

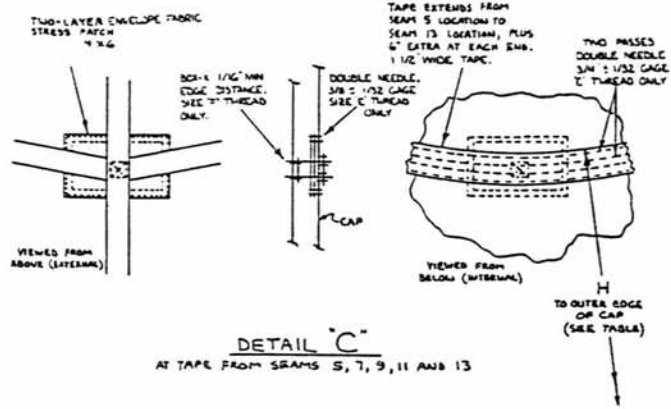

DETAIL "C"
AT TAPE FROM SEAMS 5, 7, 9, 11 AND 13

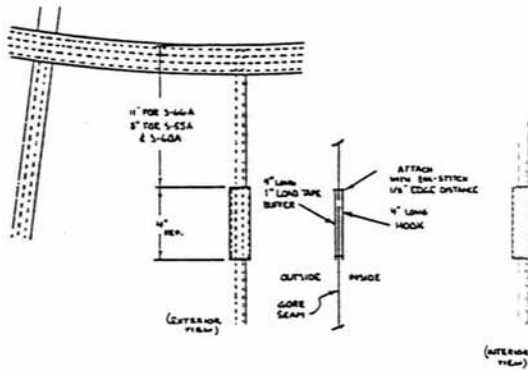

DETAIL D
DETAILS OF TOP PORT, VENT PANEL

ENVELOPE PART NO./MODEL	H DIM. INCHES	R DIM. INCHES	(REF INFO)
D-11813/S-55A	76	91	
D-10428/S-60A	78.50	94.50	
D-17653/S-66A	81	106.50	

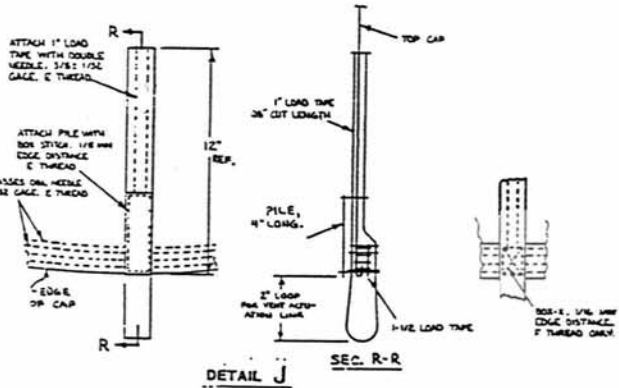

DETAIL J

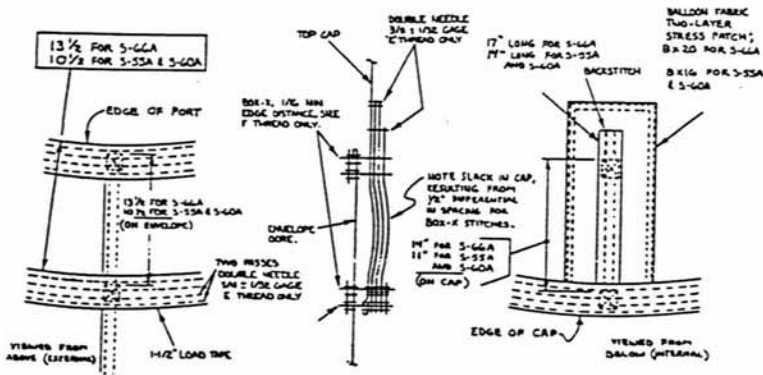

DETAIL "T"
AT SEAMS 18 AND 48

S-SERIES
DETAILS ONLY

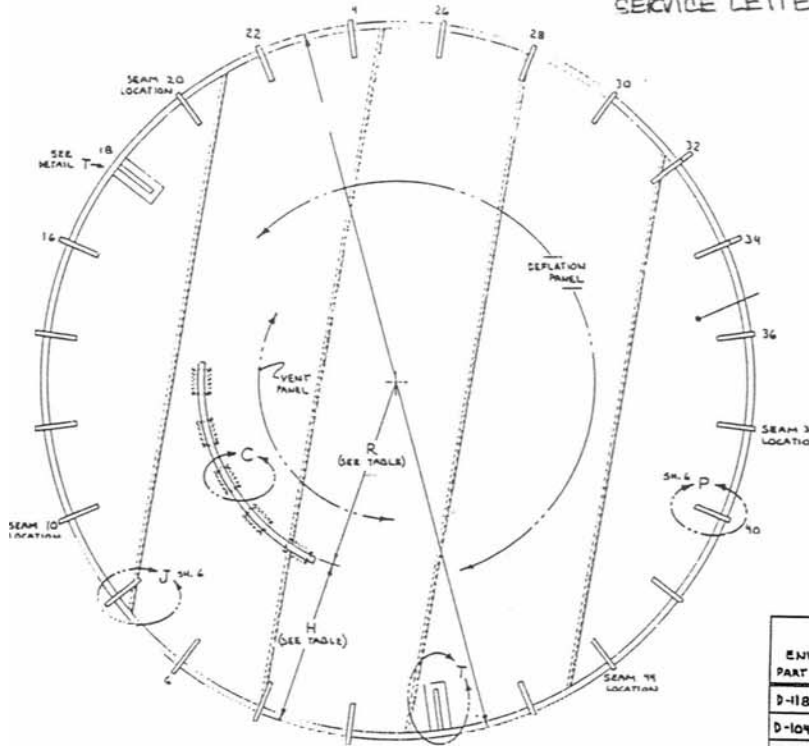

ENVELOPE PART NO./MODEL	H DIM. INCHES	(REF INFO) R DIM. INCHES
D-11813 / S-55A	76	91
D-10420 / S-60A	78.50	94.50
D-17653 / S-66A	81	106.50

CAP
VIEWED FROM BELOW
24-GORE ENVELOPE; S-55A, S-60A

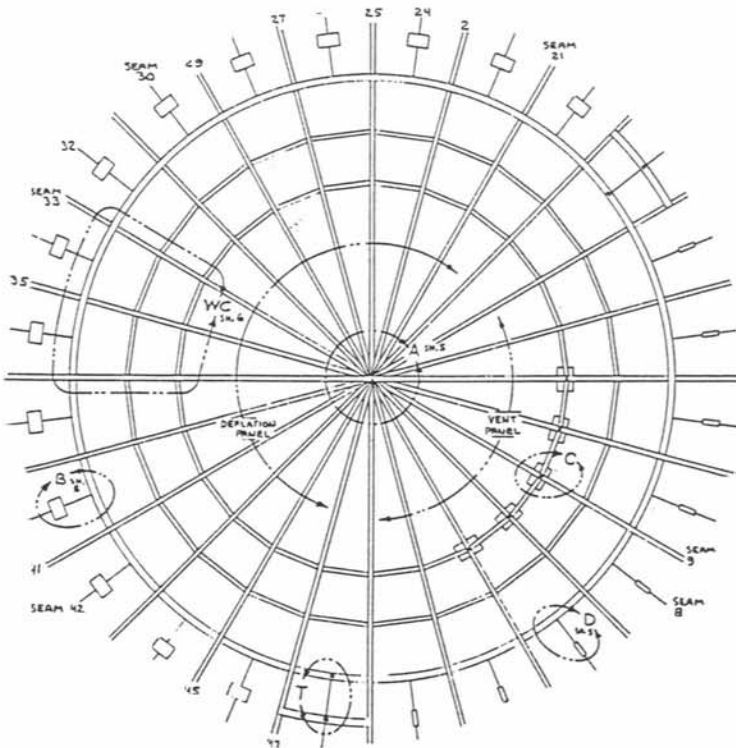

PORT AND CAP
VIEWED FROM ABOVE
24-GORE ENVELOPE S-55A, S-60A.

S SERIES
DETAILS ONLY

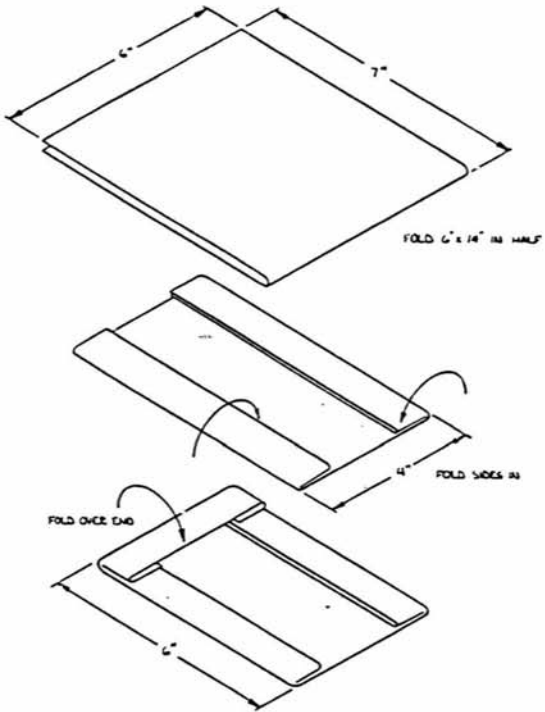

DETAIL B
FORMING 4" x 6" BUFFER FROM 6" x 14" BALLOON PACK

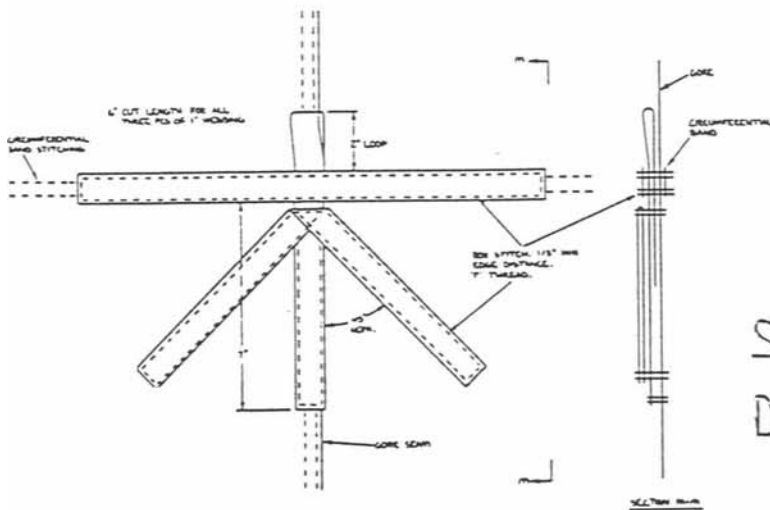

DETAIL S

S-SERIES
DETAILS ONLY

INSTRUCTIONS TO UPGRADE PARAVENT OF MODEL RX-7 ENVELOPE

These instructions define the method which is being used at the time of issuance of this letter to install the deflation/vent panel. Balloons which were built prior to April 1986 may be refitted as described herein.

Before starting this retrofit, verify that the cap to envelope attachment is not as described in Detail "T1". If your envelope is attached as depicted, the Paravent is the latest revision.

1. Begin by preparing the parts needed:

2 pcs. 1" webbing 14" long

2 pcs. 1" webbing 28" long

6 pcs. 1" webbing 16" long

1 pc 1" velcro pile 4" long

1 pc 1" velcro hook 4" long

2 pcs balloon fabric 8" x 32" color matched to top cap

3 pcs balloon fabric 6" x 14" color matched to top cap

Before proceeding any farther, verify that the seam locations are marked on the edge of the top cap for the middle of gore 11, seam 12B, 1B, 2B, 3B, middle of gore 3 and seam 4B. Number if not previously numbered.

2. Detach the top cap from the envelope by carefully cutting the stitching away that fastens the two together. Leave the 1-1/2 webbing buffer on the outside of the envelope.

3. Detach the top cap from the spider webbing by cutting the bartack stitching.

NOTE:

All sewing performed in the following steps to use type 301 stitch.

4. Prepare the cap for reattachment to the envelope.
 - a. At seams 11 and 4b cut the stitching to free the 1-1/2" webbing away from the cap about 5" to 6" in both directions.
 - b. Fold the 8" x 32" fabric in half to form an 8" x 16" double layer buffer. Sew this to the cap underneath the 1-1/2" webbing as shown in details T1 and T2 with a 3/8" gage stitch and "E" thread.
 - c. Sew the 14" long 1" webbing on next with a 3/8" gage and "E" thread, backstitching the free end. Sew the 1-1/2" webbing back down to the cap with a 3/4" gage and "E" thread.
5. The next task is to prepare the cap for reattachment to the spider web
 - a. Locate the center of the top cap. Project a radial from seam 1B to the top cap center. Mark the location along this radial at 72 1/2" from the center (65 " from edge). Do the same for seams 2B and 3B. Then strike an arc from 1B through 3B.
 - b. Mark locations for the 4" x 6" fabric buffers at intersections of arc and radials marked in (a).
 - c. Fold the 6" x 14" pieces as shown in detail B to make buffers that measure 4" x 6". Hold the folds in place with pins and sew them in place with 3/8" gage and "E" thread. See detail C.
 - d. Sew the 1-1/2" buffer web from seam 1B to 3B starting 6" from 1B and extending 6" beyond 3B with 3/4" gage and "E" thread following the arc marked in (a).

** Do not remove the original 1-1/2" buffer web or buffer patches from cap.

6. Attach the 28" long webbings to the cap to provide the loops for the vent side lines. See detail J.
 - a. Sew on the webbing with 3/8" gage "E" thread first, backstitch the ends.
 - b. Use a single needle machine with "F" thread to sew a box-X at the position shown in detail J.
 - c. Finally, sew on the 4" long pile at gore 12 location with a box stitch as shown in detail J, single needle with "F" thread.
7. Install two "stickmen" at station 64.75 at seam 12B and middle of 3. Refer to detail "S". Note: this is a simplified version which does not require a zig-zag stitch. Use a single needle with "F" thread.
8. Sew the piece of 4" velcro hook on the inside of the envelope with the 4" webbing buffer on the outside at seam 12B, 7-3/4" down from the port opening. See details D, E and F. Use a single needle with "F" thread.
9. Attach the top cap to the envelope. Perform this operation at the centerline of gore 11 (detail T1) and seam 4B (detail T2).
 - a. Sew the edge of the cap to the envelope with a box-x where the 1-1/2" webbing buffer is located on the outside. Single needle "F" thread.
 - b. Place the foot of the machine on the first box-x and pulling the cap and envelope fabric taut, make a mark on the cap at the edge of the port opening.
 - c. Measure 1/2" further away from the box-x and make another mark.
 - d. Slide the cap under the port opening until the edge lines up with the second mark and sew the two together with another box-x.
10. Attach the top cap to the spider web with a box-x stitch as shown in detail C. Single needle with "F" thread.
11. Attach the parachute lines to the cap with a beckett's loop, then to the "stickmen" with a bowline loop, and the other end to the pull line with another bowline loop. The length from cap to stickman is 111" at 12b and 107" at seam 3. From cap to pull line is 14'-0" at 12b and 18'-0" at seam. Dimensions are measured loop to loop. Safety knots at all bowline knots.

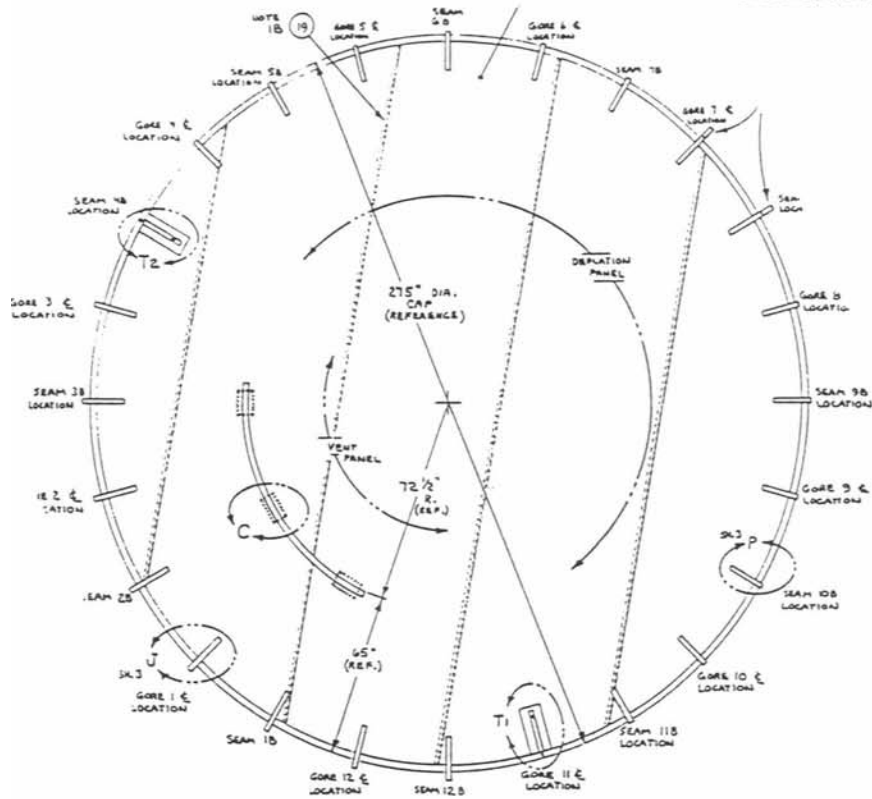

CAP
VIEWED FROM BELOW

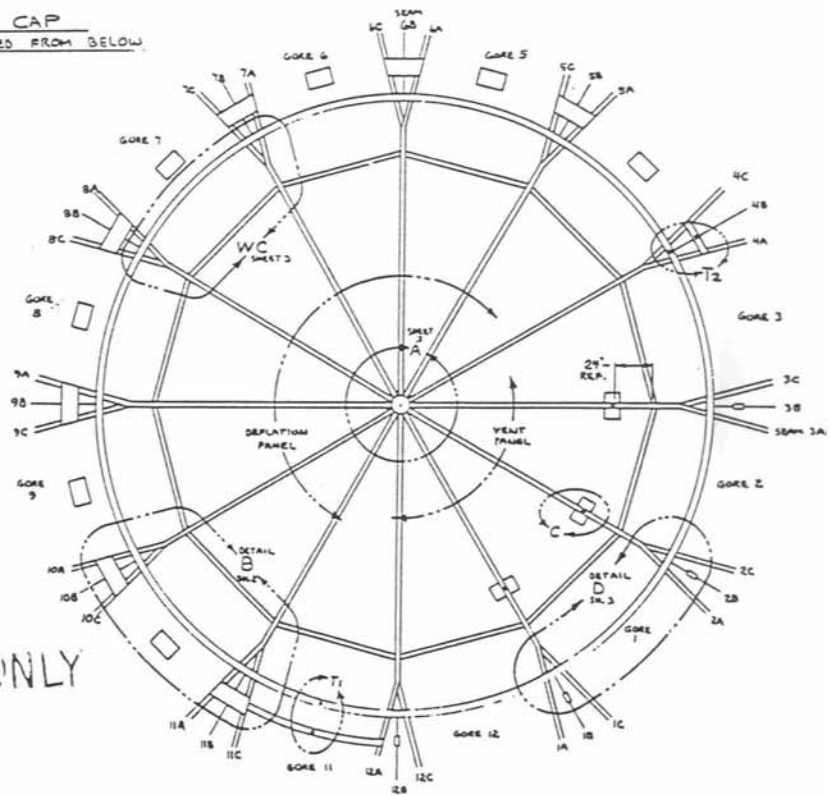

RX-7 DETAILS ONLY

PORT AND CAP
VIEWED FROM ABOVE

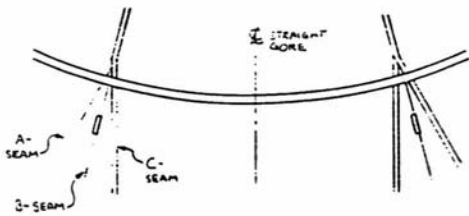

DETAIL D
 TYPICAL DETAILS OF TOP PORT,
 VENT PORTION, EXTERNAL.
 (SEE DETAIL E FOR RELATED INTERNAL DETAILS)

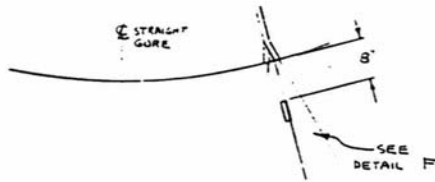

DETAIL E
 VENT PORTION OF TOP PORT, INTERNAL VIEW
 (SHOWING LOCATION OF POSITIONER FASTENING TAPE
 FROM EDGE OF TOP PORT, AT SEAMS 12B, 18, 28 AND 38.)

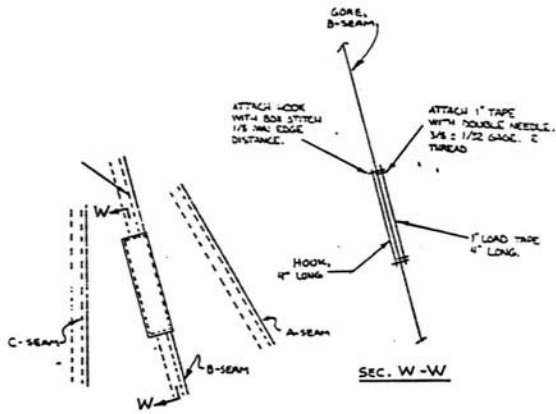

DETAIL F
 PLACES; AT SEAMS 12B, 18, 28 & 38

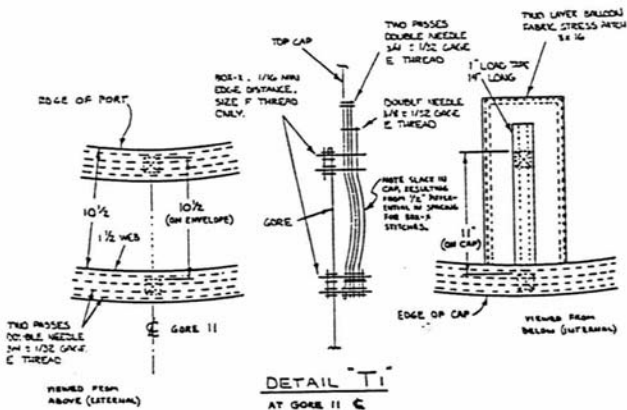

DETAIL T1
 AT GORE II

RX-7 DETAILS ONLY

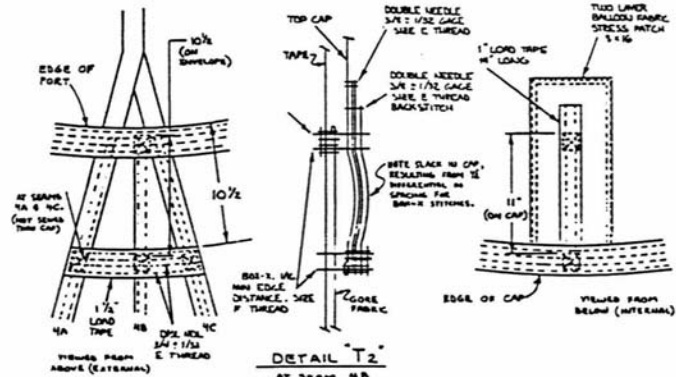

DETAIL T2
 AT SEAM 4B

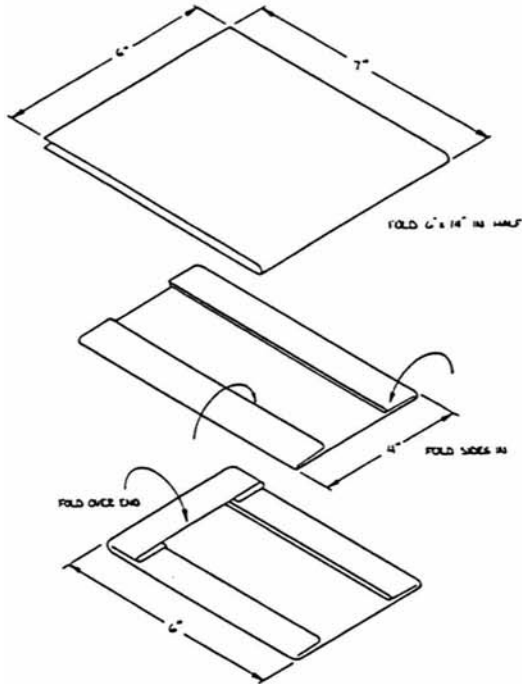

DETAIL B
FORMING 4"x6" BUFFER FROM 6"x14" BALLOON PADAK

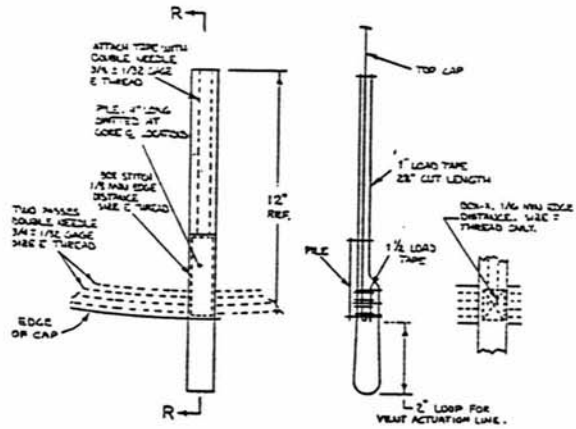
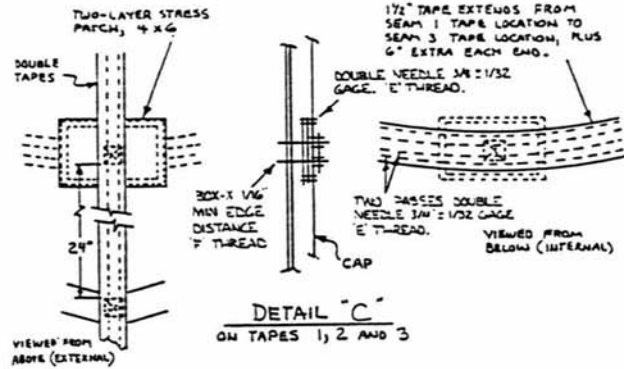

DETAIL J SEC. R-R
LOOP FOR VENT ACTUATION LINE: 8 PLACES.
ITEM 27 INCLUDED AT SEAMS 12B, 18, 28 & 38 LOCATIONS, AND OMITTED AT GORES 12, 1, 2 AND 3 LOCATIONS.
SEE D-52014 FOR DETAILS OF VENT ACTUATION LINES.

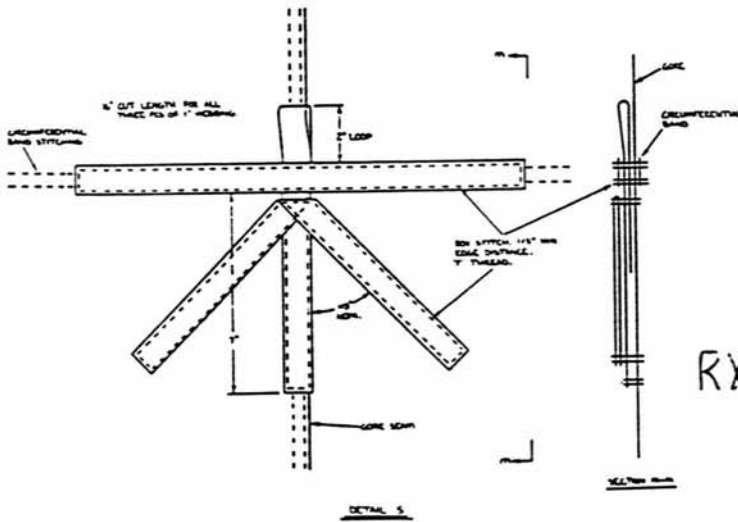

RX-7 DETAILS ONLY