

RAVEN INDUSTRIES, INC.

RAVEN

P.O. Box 1007 Sioux Falls, South Dakota 57117
Telephone (605) 336-2750 TWX910-660-0306

1 June 1984

TO: Raven Superpressure Owners

SUBJECT: Service Bulletin No. 116

This is to inform you of a potential problem with the blower on your superpressure system. To date, no failure has occurred, but Raven feels there is a remote possibility for failure in systems as described below.

The supplier of the fan for this system has modified the fan hub dimensions slightly without any notification. The dimension change is pictured on the enclosed service bulletin as dimension "H" which was originally 1.45 inches. This change makes the thickness of the spacer very critical.

With the original 1.45 inch fan hub, the original spacer (.55 inch) brought the upper face of the fan hub flush or nearly flush with the motor shaft. The more recent fan hub with the .55 inch spacer brings the upper face as much as 3/8 inch above the motor shaft end. Consequently, it is possible that the hub set screws will only contact partially with the motor shaft end key. This means the fan could come loose over a period of time.

Unfortunately, this problem is not visible unless the system is disassembled as described in the service bulletin. Because the supplier is unable to place a date on the dimension change, the service bulletin is addressed to owners of HP II superpressure systems with serial numbers through HP2C-164. Please comply with the instructions in the enclosed service bulletin NO LATER THAN JUNE 30, 1984.

We feel this situation is unfortunate and apologize for this oversight. Raven has a strong commitment to safety. We ask that you give this matter your immediate attention, so that it will not become anything more serious than a "potential problem."

Keeping Raven above the rest,



Richard A. Andrews
Project Engineer, Hot
Air Balloons
Applied Technology Division

RAA:gcl
Enc.

RAVEN[®]

industries, inc.

1 June 1984

SERVICE BULLETIN 116

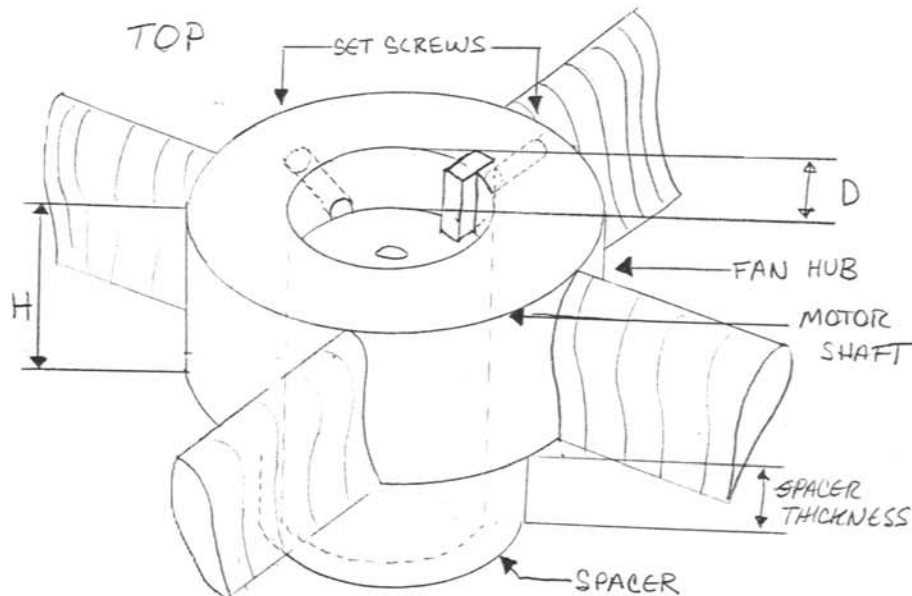
SUBJECT Superpressure Blower**APPLICABILITY** Raven Burner Models HP2C-101 to 164**PROBLEM** Change in dimension of fan hub affects position of upper face fan hub to motor shaft.**CORRECTIVE ACTION**

1. Remove blower assembly from burner.
2. Remove 10 cap screws which retain upper screen on top side of blower. Remove screen.
3. Using above illustration as a guide, measure distance D, shaft depth. If this distance is greater than 3/16 inch, proceed to step 5.
4. If distance D is 3/16 inch or less, the fan hub distance H is nominally 1.45 inches which is acceptable. Fill out the blower card and check the box marked "Spacer not required." Replace the blower screen and snug the cap screws. Please return the card to Raven.
5. If distance D is greater than 3/16 inch, fill out the blower card and check the box marked "Spacer required." If rapid service is needed, call Raven and request a new spacer. It



industries, inc.

SERVICE BULLETIN

- 2 -

1 June 1984

will be sent immediately to the repair station which is to perform the replacement.

DO NOT USE YOUR BLOWER until a new spacer is installed.

When the new spacer has been received, the repair station should follow steps 6 and 7:

6. Remove fan and hub. This may be done first by loosening two set screws several turns and then using a puller, such as a gear puller, steering wheel puller or another type.
7. Remove the old spacer and replace with new spacer. Replace fan, hub and key. Tap hub gently with a hammer to seat the assembly onto the spacer. (Check to be sure the fan blades do not hit the motor mount bolt-heads during rotation.) Tap key gently into place so it is flush with the face of the hub. Tighten set screws and replace upper screen and cap screws.
8. Please return the "Work Performed" card to Raven with the appropriate information.

Thank you for your assistance in eliminating this possible problem.
